

°C

%RH

SHIMADEN

Series SR73A & SR74A

SHIMADEN DIGITAL CONTROLLER



CE & SP[®] NRTL/C approved

BASIC FEATURES

- Low Cost with Interface Function**
- Auto / Manual control is balanceless and bumpless.**
- Multi-input and multi-range performance**
- Includes a new processing system, Expert PID, remarkably improved PID control efficiency; overshoot and undershoot are controlled effectively.**
- The keylock function can avoid erroneous operation resulting from set values or parameter settings.**
- The PV bias function can correct errors caused by sensor input.**
- A wide selection of additional functions (optional) is available to suit various needs.**

SPECIFICATIONS

Display

- Digital display: Measured value (PV)7-segment green LED 4 digits
Set value (SV)7-segment orange LED 4 digits
- Parameter display: 7-segment LED for PV and SV
- Action display: Green LEDs for 5 points of output (OUT), auto tuning (AT), stand-by mode (STBY), communication (COM) and manual output (MAN). Red LEDs for 2 points of alarm (AH, AL / HB).
- Display accuracy: $\pm(0.5\% \text{ FS} + 1 \text{ digit})$ excluding cold junction temperature compensation accuracy in the case of the thermocouple input. $\pm 5\% \text{ FS}$ for temperatures below $400^\circ\text{C}(750^\circ\text{F})$ of thermocouple B.
- Display accuracy range: $23\pm 5^\circ\text{C}(18\sim 28^\circ\text{C})$
- Display resolution: Depends on measuring range (0.001, 0.01, 0.1, 1)
- Measured display range: $-10\sim 110\%$ ($-210\sim 680^\circ\text{C}$ for $-200\sim 600^\circ\text{C}$ of R.T.D. input)

Setting

- Setting: By 5 front key switches
- Setting range: Same as measuring range.

Input

- Type of input: Multiple input of Thermocouple, R.T.D., Voltage (mV), or Voltage (V), or Current 4~20mA DC by code selection
- Thermocouple: B, R, S, K, E, J, T, N, {U, L(DIN 43710)} Refer to Measuring range code table.
External resistance: 100 Ω max.
Input impedance: 500k Ω min.
Burnout: Standard feature (up scale)
Cold junction temperature compensation accuracy: $\pm 2^\circ\text{C}$ (5~45 $^\circ\text{C}$)
 $\pm 5^\circ\text{C}$ to the negative side of measuring range in case of T and U input.
- R.T.D.: JIS Pt100 / JPt100 3-wire type
Amperage: Approx. 0.25mA
Lead wire tolerable resistance: 5 Ω max. / wire (The 3 lead wires should have same resistance.)
- Voltage: 0~10, 10~50, 0~100mV DC or 0~1, 1~5, 0~10V DC
Input impedance: 500k Ω min.
- Current: 4~20mA DC
Receiving impedance: 250 Ω
- Input scaling function: Scaling possible for voltage (mV, V) or current (mA) input.
Scaling range: $-1999\sim 9999$ counts.
Span: 100~5000 counts
Position of decimal point: None, 0.0, 0.00, 0.000
- Sampling cycle: 0.5 sec.
- PV bias range: ± 200 unit
- PV filter: 0~100 sec. (0=without filter)

Control

- Control mode: Auto tuning PID / ON-OFF control
- Proportional band (P): Off, 0.1~999.9% FS (Off setting: On-Off action)
- Integral time(I): Off, 1~6000 sec. (Off setting: P-PD action)
- Derivative time (D): Off, 1~3600 sec. (Off setting: P-PI action)
- Manual reset (MR): $-50.0\sim 50.0\%$ (Valid when P \neq OFF and I=OFF)
- Output limiter: Lower limit limiter 0~99%, Higher limit limiter 1~100% (Priority given to lower limit limiter)
- Soft start of output: Off, 1~100 sec.
- ON / OFF hysteresis: 1~999 units.
- Proportional cycle: 1~120 sec. (Factory-set value: 30 sec. for contact output and 3 sec. for SSR drive voltage output.)
- Control output characteristics: RA / DA selectable (set to RA when shipped)
- Set value function (SF): OFF(Off=0.00) and 0.01~1.00

Control Output

- Contact output: 240V AC 2.5A / resistive load: 1.5A / inductive load
- Current output: 4~20mA DC / load resistance: 600 Ω max.
- SSR drive voltage output: 15 \pm 3V DC (with load resistance at 1.5k Ω) / load current: 20mA maximum
- Voltage output: 0~10V DC / load current: 2mA maximum

Manual Control

- Output setting range: 0~100% (setting resolution: 1%) but within range set by higher / lower output limiters.
- Auto / manual switching: Balanceless bumpless. Within proportional band range.

Communication (Optional)

- Signal level: EIA standards, conforming with RS-422A and RS-485.
- Communication System: RS-422A 4-wire half duplex multi-drop system. RS-485 2-wire half duplex multi-drop (bus) system.
- Synchronous system: Start-stop synchronous system.
- Data format: Data length 7 bits, even parity, stop bit 1.
- Communication address: Machine numbers are set in a range from 0 to 99
- Communication rate: 1200, 2400, 4800 and 9600 bps.
- Communication delay: To be set in a range from 0 to 255 (Setting possible only in the case of RS-485.)
- Communication distance: RS-422A maximum 1200m (depending on conditions) RS-485 maximum 500m (depending on conditions)
- Transmission procedure: No procedure.
- Communication code: Conforming with ASCII codes.
- Control signal: Not used.
- Error detection: Vertical parity (even parity) checking. BCC (block check character) checking.
- Connectable number of apparatuses: Possible to connect 100 units maximum (including the host, depending on conditions)

Alarm Output (Option)

- Number of alarm points: 2 (AH and AL / HB, both for normal open and common)
- Alarm Type: Selectable from the following 9 combinations. (5 through 8 are selectable only when apparatus has heater break alarm function.)
 0. Not assigned
 1. Higher limit deviation value + lower limit deviation value without inhibit action
 2. Higher limit absolute value + lower limit absolute value without inhibit action
 3. Higher limit deviation value + lower limit deviation value with inhibit action
 4. Higher limit absolute value + lower limit absolute value with inhibit action
 5. Higher limit deviation value without inhibit action + heater break
 6. Higher limit absolute value without inhibit action + heater break
 7. Higher limit deviation value with inhibit action + heater break
 8. Higher limit absolute value with inhibit action + heater break
- Alarm setting range: Higher limit and lower limit absolute value alarms: Within full scale of measuring range
- Deviation value: Higher limit: 0~2000 unit
Lower limit: -1999~0 unit
- Alarm action: On-Off action
- Alarm action hysteresis: Fixed to 0.2% of the measuring range
- Alarm output / rating: Contact 1a (common) / 240V AC 1.5A (resistive load)

Heater Break Alarm (option)

This function can be added if the instrument has an alarm option and the control output is the contact type or the SSR drive voltage type.

- Alarm action: Heater amperage detected by externally attached CT. (except 0~5V DC input) Alarm output On upon detection of heater break while control output is On.
- Current setting range: Off, 0.1~50.0A (Alarm action stops when Off is set.) or, Off, 1~500A (when 0~5V DC for CT input is selected)
- Setting resolution: 0.1A or 1A
- Amperage display: 0.0~55.0A or 0~550A
- Display accuracy: 5% FS (when sine wave is 50 Hz) or 1% FS (in case of 0~5V DC input)
- Minimum time for action confirmation: On time: 500 msec.
- Alarm holding: Selectable between Lock (holding) and Real (no holding)
- Sampling cycle: 2 sec.

Set Value Bias (Option)

- Setting range: -1999~2000 unit
- Setting resolution: Same as display resolution
- Action input: Non-voltage contact (bias in action when SB terminal is closed)

Others

- Data storage: By non-volatile memory (EEPROM)
- Isolation: Input, control output, communication and alarm output circuits are isolated from each other. Input, set value bias and CT input circuits are not isolated from each other.
- Ambient conditions for use Temperature/humidity ranges: -10~50°C and below 90%RH (on the condition that there is no dew condensation)
- Height: 2000 m above sea level or lower
- Installation category: II
- Degree of pollution: 2
- Supply voltage / frequency: 100-260V AC±10% (50 / 60 Hz)
- Power consumption: 12 VA max.
- Applicable standard: Safety: IEC1010-1
EMC EMI (emission): EN50081-1
EMS (immunity): EN50082-2
- Insulation resistance: Between input / output terminal and power supply terminal: 500V DC 20 MΩ minimum
Between input / output terminal and protective conductor terminal: 500V DC 20 MΩ minimum
- Dielectric strength: 1 min. at 2300V AC between input / output terminal and power supply terminal 1 min. at 1500V AC between power supply terminal and protective conductor terminal
- Protective structure: Only front panel has simple dust-proof and drip-proof structure
- Material: PPO resin molding (equivalent to UL94V-1)
- External dimensions
SR73A: H96 × W96 × D110 (panel depth: 100)mm
SR74A: H96 × W48 × D110 (panel depth: 100)mm
- Mounting: Push-in panel (one-touch mount)
- Panel thickness: 1.0~3.5 mm
- Panel cutout
SR73A: H92 × W92mm
SR74A: H92 × W45mm
- Weight
SR73A: Approx. 400g
SR74A: Approx. 300g

Alarm Method	Alarm Setting Range	Action
Higher limit deviation value alarm	0~2000 unit	OFF ON
Lower limit deviation value alarm	-1999~0 unit	ON OFF
Higher limit absolute value alarm	within measuring range	OFF ON
Lower limit absolute value alarm	within measuring range	ON OFF

△ Main setting ▲ Alarm setting

Alarm Type:

•Selectable from combination of the following 9 types

Alarm code	AH assignment	With/Without inhibit action	AL/HB assignment	With/Without inhibit action
0 (0)	Not assigned	-----	Not assigned	-----
1 (1)	Higher limit deviation value	Without inhibit action	Lower limit deviation value	Without inhibit action
2 (2)	Higher limit absolute value	Without inhibit action	Lower limit absolute value	Without inhibit action
3 (3)	Higher limit deviation value	With inhibit action	Lower limit deviation value	With inhibit action
4 (4)	Higher limit absolute value	With inhibit action	Lower limit absolute value	With inhibit action
5 (5)	Higher limit deviation value	Without inhibit action	Heater break	-----
6 (6)	Higher limit absolute value	Without inhibit action	Heater break	-----
7 (7)	Higher limit deviation value	With inhibit action	Heater break	-----
8 (8)	Higher limit absolute value	With inhibit action	Heater break	-----

Alarm setting range:

Higher limit and lower limit absolute value alarms: Within measuring range

Deviation value: Higher limit: 0~2000 unit*

Lower limit: -1999~0 unit*

} In case SV is out of the measuring range, higher and lower limit values of the measuring range become the action points.

Alarm action:

On-Off action

Alarm action hysteresis:

Fixed to 0.2% of the measuring range

Alarm output / rating:

Contact 1a (common) / 240V AC 1.5A (resistive load)

WIRING EXAMPLE I

•Contact output (Y1)

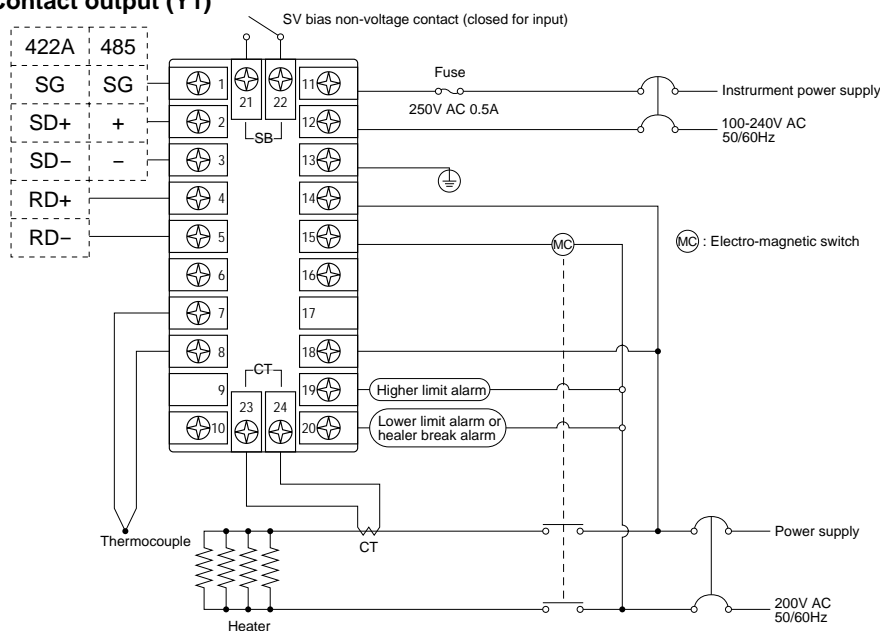

Note:

- The heater break alarm function (optional) can be added when the control output is of the contact (Y1) or the SSR drive voltage (P1) type.
- Fuse: Since the instrument does not have a built-in fuse, do not forget to install a fuse in the power circuit to be connected to the power terminal. The fuse should be positioned between the switch or the breaker and the instrument and be attached to the L side of the power terminal. Fuse Rating: 250V AC 0.5A / medium lagged or lagged type. Use a fuse which meets the requirements of IEC127.

**•Current output (I1)
Control output portion only**

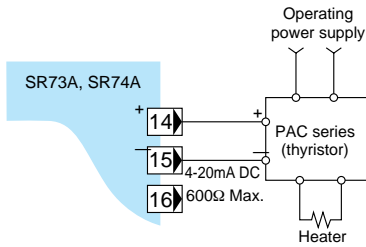

**•SSR drive voltage (P1)
Control output portion only**

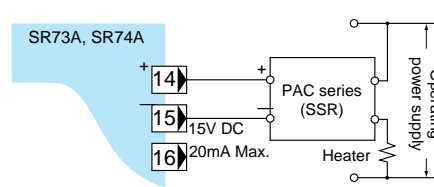

WIRING EXAMPLE II

□ How to connect SR73A or 74A with host computer

• Control signals

Since the apparatus is provided with input / output transmitting and receiving data lines and an earthing line for signals but not with any other signal line, control signals should be processed by the host side.

The method of processing differs from system to system and connection details should meet requirements of the host computer. Examples of connection are shown in the following.

• Connection of RS-422A

(1) The logical levels of input and output of this apparatus are basically as follows:

Mark state ****-<***** (Example: SD-<SD+)

(including the state in which communication is not carried out)

Space state ****->***** (Example: SD->SD+)

However, since the impedance of SD+ and SD- of this apparatus is high until just before transmission, the above levels are output just before commencing transmission.

(2) Example of Connection of RS-422A

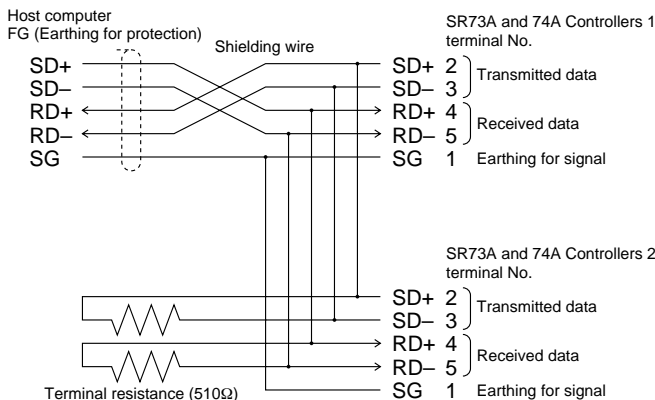

Note: Some line converters between RS-232C and RS-422A may have the following indication for terminal (connector) output. If that is the case, logical levels should be checked before connection.

Example: Mark state T x D+ > T x D-
Mark state T x D+ < T x D-

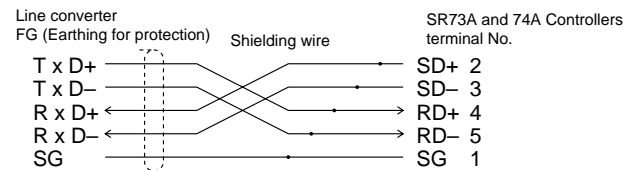

• Connection of RS-485

(1) The logical levels of input and output of this apparatus are basically as follows:

Mark state -Terminal < + Terminal

(including the state in which communication is not carried out)

Space state -Terminal > + Terminal

However, since the impedance of +terminal and -terminal of this apparatus is high until just before transmission, the above levels are output just before commencing transmission.

(2) Example of Connection of RS-485

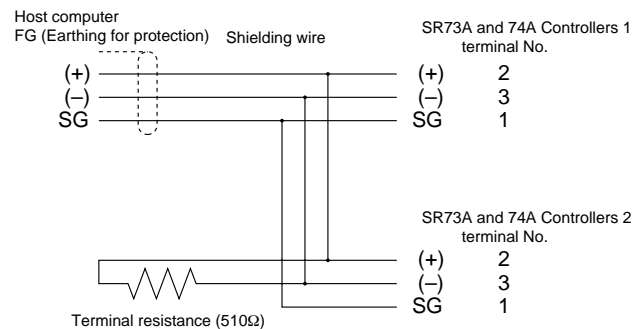

• Terminal resistance

As SR73A and SR74A are not provided with terminal resistance, connect a 510Ω resistance to only the last (the furthest from the host) station.

Note: If terminal resistance is connected to two or more, correct action is not guaranteed.

ITEM	CODE		SPECIFICATIONS	
SERIES	SR73A-		H96 × W96 × D110 DIN size digital controller for auto tuning with interface function PID control	
	SR74A-		H96 × W48 × D110 DIN size digital controller for auto tuning with interface function PID control	
INPUT	8		·Thermocouple B, R, S, K, E, J, T, N {U, L (DIN43710)} Multi input ·R.T.D. Pt100/JPt100 ·Voltage (mV) 0~10, 10~50, 0~100mV DC	Value set at K 0~1200°C when shipped
		4	Current (mA) 4~20mA DC	Value set at 4~20mA/0~100.0 when shipped
		6	Voltage (V) 0~1, 1~5, 0~10V DC	Value set at 0~1 V/0~100.0 when shipped
CONTROL OUTPUT	Y1-		Contact (1c) Contact capacity : 240V AC 2.5A/resistive load Proportional cycle fixed to 20sec.	RA(heating characteristics) set when shipped
	I1-		Current 4~20mA DC Load resistance : 600Ω max.	
	P1-		SSR drive voltage Output rating : 15 ± 3V DC 20mA max. Proportional cycle fixed to 2sec.	
	V1-		Voltage 0~10V DC Load current : 2mA max.	
OPTIONAL FUNCTION	0		None	
	1		Alarm 2 points (higher and lower limits) alarm (1a) (for both normal open and common) (Deviation/absolute value and inhibit action are selectable)	·Alarm : Higher&lower limit deviation value(without inhibit action) ·Heater break alarm mode : Lock mode, set when shipped
		2	Alarm+heater break alarm (can be assigned to AL/HB) Setting range : 0.0~30.0A	
		3	Alarm+heater break alarm (can be assigned to AL/HB) Setting range : 0.0~50.0A	
	4		SV bias Setting range : -1999~2000Unit	
	5		Alarm+SV bias	
	6		Alarm+heater break alarm (30.0A)+SV bias	
	7		Alarm+heater break alarm (50.0A)+SV bias	
INTERFACE FUNCTION	5		RS-485	
	6		RS-422A	
REMARKS	C		Without (for CE Marking)	
	9		with (for remarks other than CE Marking)	

ACCESSORIES REQUIRED FOR HEATER BREAK ALARM FUNCTION (COMMON)

• CT wiring

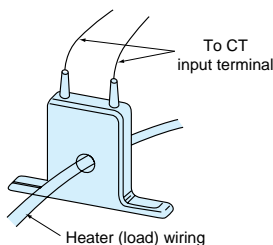

• 30A (CTL-6-S)

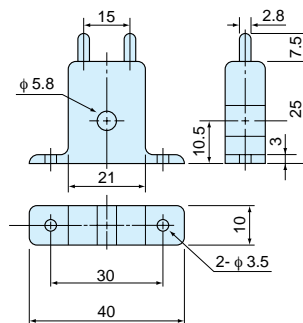

• 50A (CTL-12-S36-8)

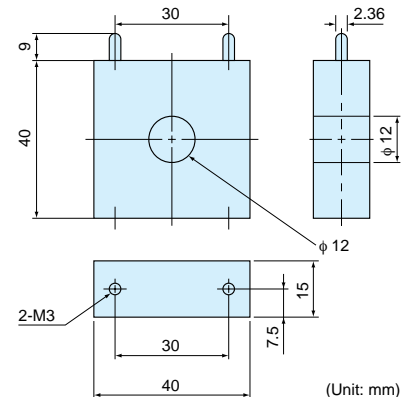

(Unit: mm)

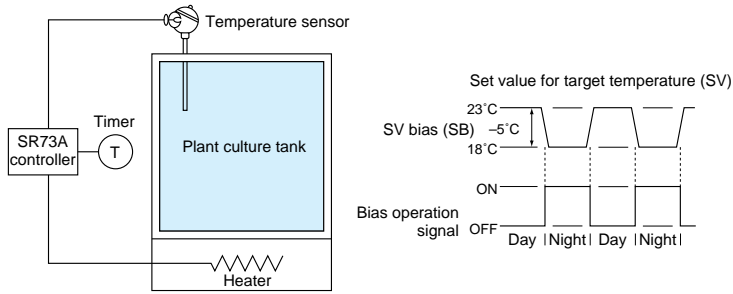

SR73A AND SR74A

•SR73A

External Dimensions

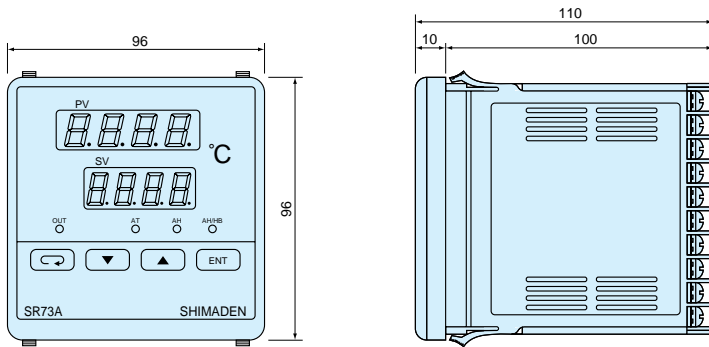

Panel Cutout

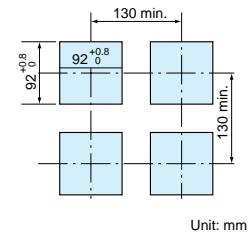

•SR74A

External Dimensions

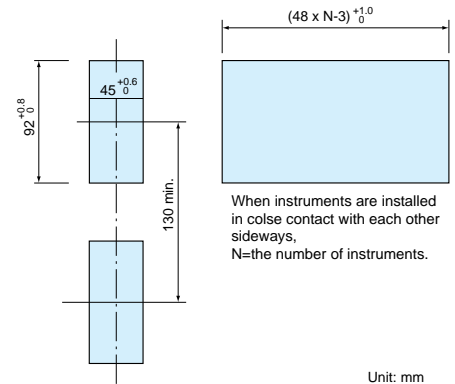
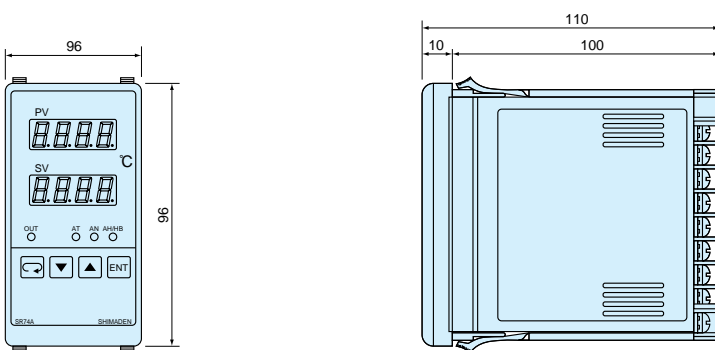

Terminal arrangement

•SR73A

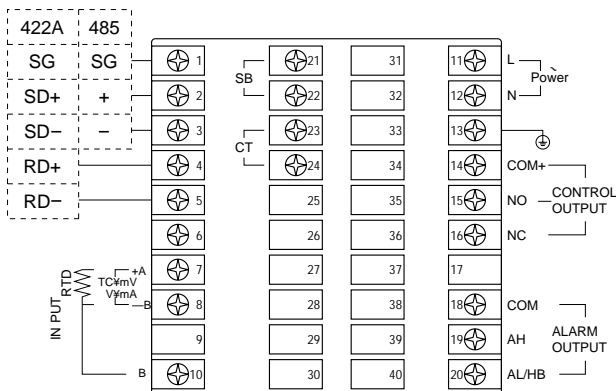

Terminal arrangement

•SR74A

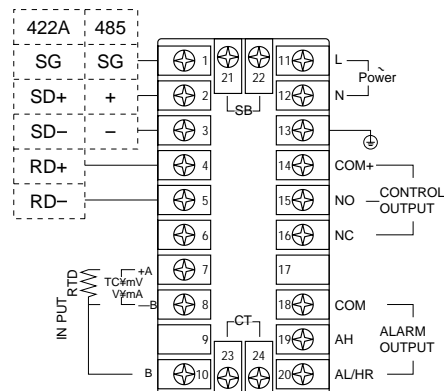

	Input type	Code	Measuring Range	Code	Measuring Range	
Multi input	Thermocouple	*1B	01	0~ 1800°C	12	0~ 3300°F
		R	02	0~ 1700°C	13	0~ 3100°F
		S	03	0~ 1700°C	14	0~ 3100°F
		K	04	-100~ 400°C	15	-150~ 750°F
		K	05	0~ 1200°C	16	0~ 2200°F
		E	06	0~ 700°C	17	0~ 1300°F
		J	07	0~ 600°C	18	0~ 1100°F
		T	08	-199.9~ 200.0°C	19	-300~ 400°F
		N	09	0~ 1300°C	20	0~ 2300°F
		*2U	10	-199.9~ 200.0°C	21	-300~ 400°F
		*2L	11	0~ 600°C	22	0~ 1100°F
	R. T. D.	Pt100	31	-200~ 600°C	39	-300~ 1100°F
			32	-100.0~ 100.0°C	40	-150.0~ 200.0°F
			33	-50.0~ 50.0°C	41	-50.0~ 120.0°F
			34	0.0~ 200.0°C	42	0~ 400°F
		JPt100	35	-200~ 600°C	43	-300~ 1100°F
			36	-100.0~ 100.0°C	44	-150.0~ 200.0°F
			37	-50.0~ 50.0°C	45	-50.0~ 120.0°F
			38	0.0~ 200.0°C	46	0~ 400°F
Voltage mV	0~ 10	71	Initial value : 0.0~100.0 Conditions of scaling Scaling setting range: -1999~9999, Span: 100~5000 counts Position of decimal point: No decimal point, the first, second and third decimal places	Thermocouple B, R, S, K, E, J, T, N : JIS/ANSI/IEC R. T. D. Pt100 : Present JIS/IEC JPt100 : Old JIS *1 Thermocouple B : Accuracy not guaranteed for temperatures below 400°C(750°F) *2 Thermocouple U, L-DIN43710		
	10~ 50	72				
	0~100	73				
	0~ 1	81				
Voltage V	0~ 5	82				
	0~ 10	83				
	Current mA	4~ 20	95			

TERMINAL COVER (AVAILABLE SEPARATELY)

Model	
SR73A	SR5301-9
SR74A	SR5401-7

Material / Appearance: PVC / transparent
Thickness: 1mm

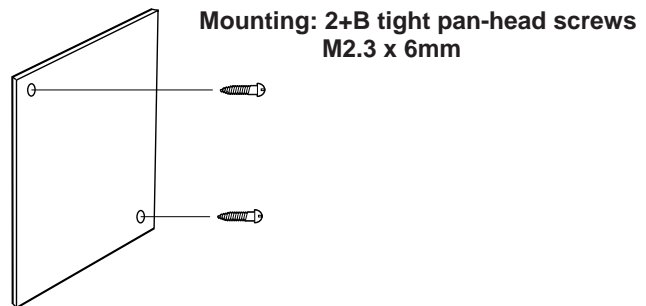

Warning

- The SR73A & SR74A series is designed for the control of temperature, humidity and other physical values of general industrial equipment. (It is not to be used for any purpose which regulates the prevention of serious effects on human life or safety.)

Caution

- If the possibility of loss or damage to your system or property as a result of failure of any part of the process exists, proper safety measures must be made before the instrument is put into use so as to prevent the occurrence of trouble.



ISO 9001

(The contents of this brochure are subject to change without notice.)

Temperature and Humidity Control Specialists

SHIMADEN CO., LTD.

Head Office: 2-30-10 Kitamachi, Nerima-Ku, Tokyo 179-0081 Japan

Phone: +81-3-3931-7891 Fax: +81-3-3931-3089

E-MAIL: exp-dept@shimaden.co.jp URL: http://www.shimaden.co.jp